

PRACTICAL WIRELESS

JANUARY
1973

20p

**FREE
COMPETITION
INSIDE**

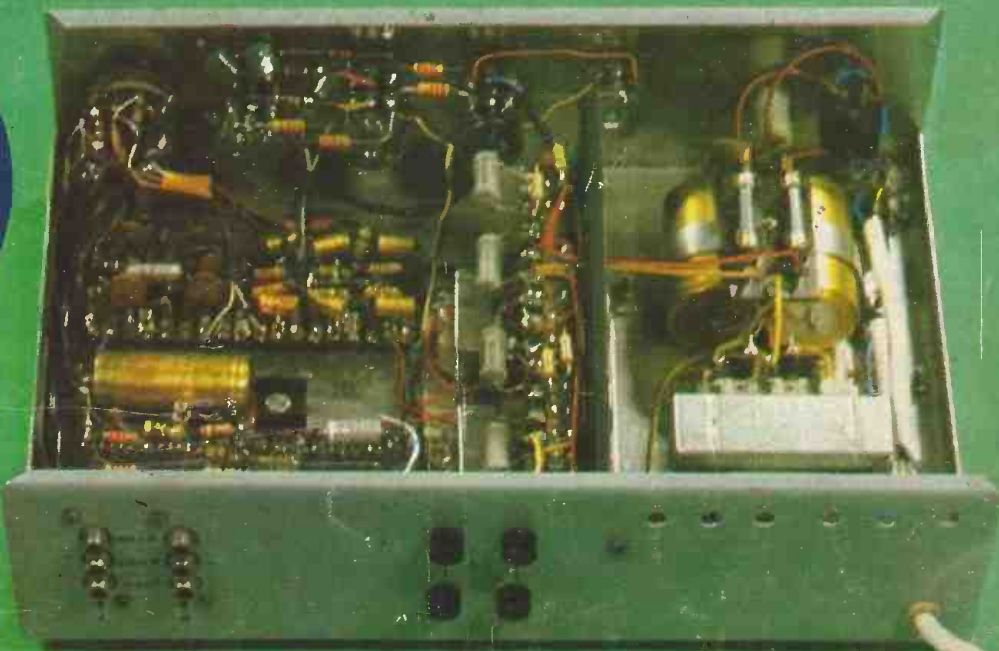

STEREO

10+10 WATT AMPLIFIER

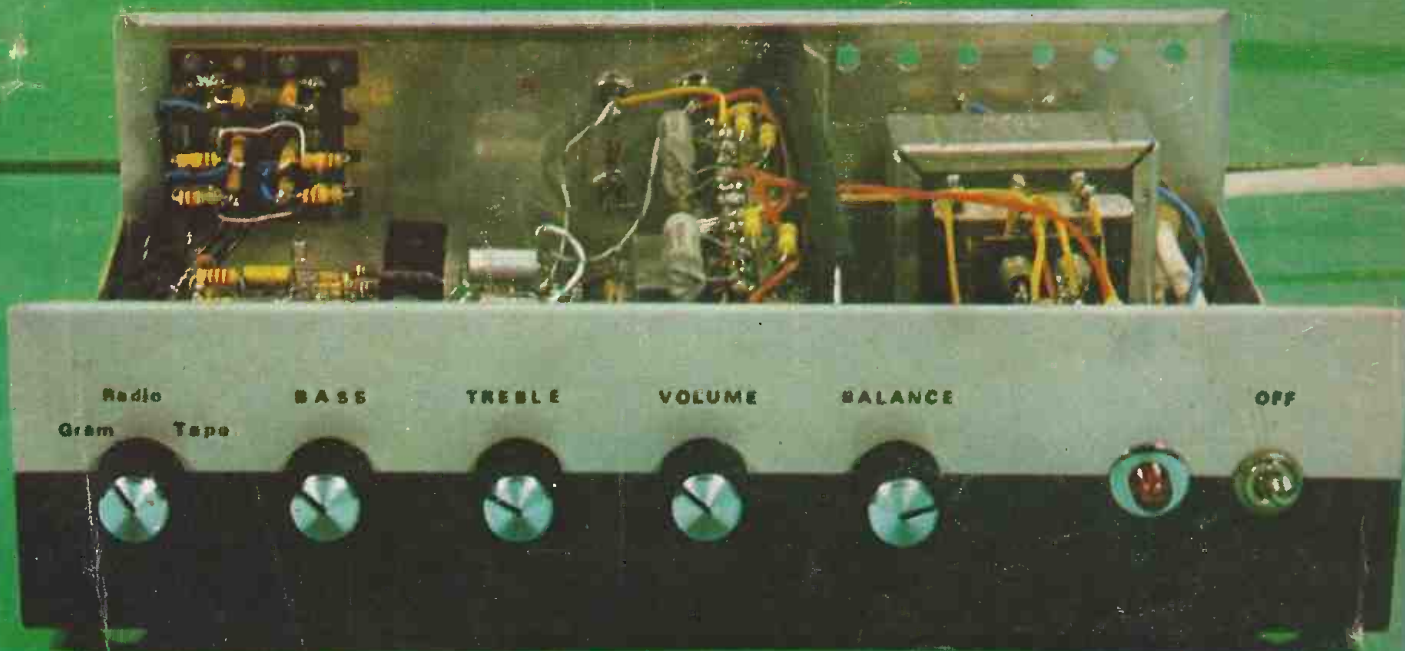

FINAL ENTRY FORM

**10 SCOPES TO
BE WON!**

ALSO:

**LINEAR CAPACITANCE METER
CONVERTER FOR 1.7-30MHz**

MANY P.W. readers must have seen 'Tomorrow's World' on BBC-1 at the beginning of November which included a demonstration of a remarkable new radio i.c. Realising that many of you will want to experiment with this, we have pulled all the stops out to bring you the 'Mighty Midget' which makes use of the hot-off-the-production-line ZN414, a remarkable little i.c. of which we are bound to hear more.

Already we are preparing further projects which use this device, including an ultra simple bed-side radio which, in conjunction with another i.c. for the

Smaller & smaller...



THE **Mighty Midget!**

HALVOR MOORSHEAD

audio amplifier, will make an excellent push-button receiver with loudspeaker output using less than 20 components.

The ZN414 is a complete a.m. radio circuit containing 10 transistors, 4 capacitors and 15 resistors. It is a t.r.f. but overcomes many of the disadvantages of this type of circuit. It does not have the performance of a superhet but it is nearer this than the conventional type of t.r.f.

For miniaturisation the ZN414 is ideal; it operates beautifully using a tiny mercury cell and the photographs show just how tiny we have made our prototype. We hesitate to make the claim that this is the "smallest radio in the world" simply because we haven't seen all the contenders! What we can say is that the 'Mighty Midget' is smaller than either of the two rival commercial claimants for this title!

Miniaturisation is fun—and novel—but usually problems are encountered in making or obtaining the 'bits'; this does not apply to the 'Mighty Midget' for, apart from the i.c. (suppliers are given in the components list), all the components are widely available and little difficulty should be experienced in obtaining them.

USING THE
ZN414 AS
FEATURED ON BBC 1's
**Tomorrow's
World**

Construction is relatively simple; all you need is a file, a couple of drills, a screwdriver, fine-nosed pliers and a soldering iron. The total cost will depend on what you already have available or where you buy your components but assuming that all-new components are used, the cost will be about £2, £1.25 of which is for the i.c.

It must be emphasised that although we are using the ZN414 here in a 'gimmick' circuit, this is by no means its main application. Ferranti, the British makers, have released few details of this device—no internal circuit has yet been made available to the public—but it offers several attractive features. The input impedance is very high—typically 1.5MΩ—and this allows for a simple tuned circuit to be connected to it without the device damping it; this accounts for the good selectivity.

There is also an excellent a.g.c. circuit built into the device; this is a feature difficult to obtain with normal t.r.f. design.

The output from the unit can be as high as 30mV but the tiny aerial used here means that the output of our unit is somewhat less. The current drain measured on the prototype was a tiny 70μA but the makers say that a more typical figure would be 400μA. Even so, the mercury cell will give over 400 hours of operation for about 16p (the cost of the battery).

Our circuit here is for medium waves only but the i.c. will operate (at lower efficiency) on the long waves and up to 5MHz. In a quick lash-up during development of the prototype, our sample even worked well on the 49 metre-band—rather above the maker's claim, though this may be a characteristic of our sample.

The selectivity of the prototype is reasonable but takes an unusual form. Although the tuning of the more powerful stations is very broad, as soon as another station of sufficient strength is tuned in, even though fairly close to the main one, there is no trace of the well-spread, powerful one. Radio 4, pretty strong in the author's area, appears across most of the dial but is not present when the receiver is tuned to other stations. This is hard to describe but those building this project will notice the effect.

The author, living in the London area, picked up over a dozen stations at one o'clock in the morning but Radio Luxembourg was not amongst these as BBC Radio London on 206 metres completely swamped it. When the latter went off the air one hour later, Luxembourg was as clear as crystal, so readers outside London and Birmingham (which also uses 206 metres) should have no problems in getting it. The weaker the station, the better the selectivity; there is definitely swamping of the front end from powerful stations and the makers admit this in their spec. sheet.

Our use of the ZN414 is obviously not the best way of demonstrating audio quality but the distortion from this unit is somewhat less than that from an ordinary superhet due to very low intermodulation distortion.

CIRCUIT

The complete circuit is given in Fig. 1. The ZN414 comes in a TO-18 can (the same as a BC109) and there are only three connections: input, negative-chassis and output-positive.

The radio signals are induced into the tiny coil, L1,

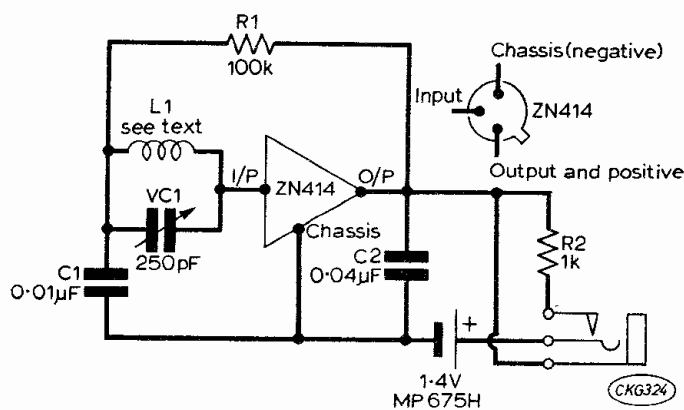

Fig. 1: The complete circuit, beautifully simple as far as the constructor is concerned yet the i.c. contains 10 transistors, 4 capacitors and 15 resistors—all on a 30 thousandths of an inch square chip.

★ components list

- | | |
|-------------------|---|
| R1 | 100kΩ, $\frac{1}{4}$ W, 5% |
| R2 | 1kΩ, $\frac{1}{4}$ W, 5% — see text |
| C1 | 0.01μF tubular ceramic |
| C2 | 0.04μF disc ceramic—see text |
| VC1 | 250pF compression trimmer (R.S. Components) |
| L1 | 90 turns of 32 s.w.g. enamelled copper wire on $\frac{1}{4}$ in. length of $\frac{1}{16}$ in. diameter ferrite rod. |
| IC1 | ZN414 (Ferranti). Available from Bywood Electronics, 181 Ebbw Road, Hemel Hempstead, Herts or Henry's Radio Ltd., 303 Edgware Road, London W.2 or Davian Electronics, P.O. Box 38, Oldham Lancs. Price (same from all suppliers) £1.25 including postage. |
| Battery | Mercury cell, 1.4V, type MP675H (available from most chemists). |
| Jack socket | 2.5mm type with switch, modified as shown. |
| Crystal earpiece | with 2.5mm jack plug; see text. |
| Case | Snuff box; see text. |
| Tuning knob | 6BA screw, $\frac{3}{16}$ in long. |
| Total cost | about £2 |

which is tuned by the variable capacitor VC1. One side of the tuned circuit connects directly to the input while the other is at chassis potential (as far as a.c. is concerned) by having C1 in line.

As the internal circuit is not available and details are at present a closely guarded secret, we can only guess at the function of R1—presumably it applies bias to the input but it may also affect the a.g.c. Experimentally it was found that lower values caused regeneration and instability but such experiments cannot be recommended as the device may be harmed.

The output is an audio signal but a small smoothing capacitor is required. The makers suggest a 0.01μF component for C2 but this was found barely sufficient and a 0.04μF (or 0.05μF) was found better. This higher value was not found to affect the audio signal. This component has been left accessible in the layout if readers wish to experiment with this value.

The reason why a higher value is better is because we are closing things up a bit tighter than is recommended; ideally the output lead of the i.c. should be at least an inch from the coil but if extra smoothing is used there is less danger of instability resulting from r.f. finding its way back to the coil. The load resistor, across which the a.f. signal is developed, is R2. The value here affects the a.g.c. and once again

there is room for experiment. As with C2, this component is left accessible for changes if necessary. The makers recommend a 470Ω here as a typical value but in the prototype the 1kΩ was found a bit better.

For efficiency and economy a crystal earpiece is used. This has a high impedance and will not affect the circuit operation. The author also tried 250Ω and 2000Ω impedance magnetic types; both worked well, although the d.c. conditions are affected and changes may be necessary in both R2 and C2 if these are used. Low impedance magnetic types which are provided with many transistor radios are *not* suitable and should not be used.

THE COIL

Commercial coils of the size that we need are not available and so it is necessary to wind one's own but this is not difficult. You need to buy a length of 1/4 in. diameter rod, this is available in 5 in. or 6 in. lengths from Henry's Radio or Home Radio but of course this has to be cut to a 1 1/2 in. length. The way to do this is to file a V-shaped groove and smartly snap the rod—it is no good trying to cut it with a hacksaw. When this is done check that it will fit inside the case before winding the coil.

A narrow band of plastic, self-adhesive tape should be wound around one end, trapping the wire in it. 90 turns of 32 s.w.g. wire should then be made, the final turn being trapped in a second band of tape. Thinner gauge wire may be used if available, but thicker gauges will not fit on, the length of the rod is not sufficient.

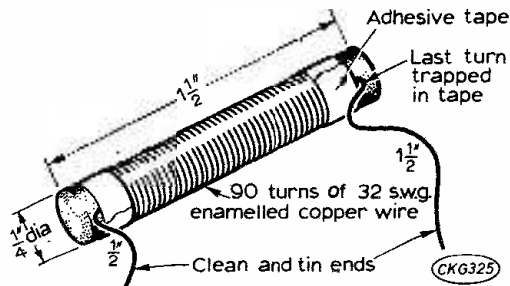

Fig. 2: The aerial is wound on a short length of ferrite rod as shown.

A drawing of the ferrite rod aerial is shown in Fig. 2 and, as will be seen, short lengths of wire should be left at both ends, stripped of the insulation and tinned.

CONSTRUCTION

The case can be obtained from nearly any tobacconist—it is the container used for Wilson's S.P. No. 1 Snuff, the most widely available brand. The cost of this—including the snuff of course—is only 8p and the little plastic box is an ideal size for our needs and quite strong. The metal lid fits tightly and no additional fixing for this is necessary. Incidentally if you haven't tried snuff, this is your chance (your author is partial to the occasional pinch).

Two holes have to be drilled in the box, these are shown in Fig. 3. The siting of the hole for VC1 has to be quite accurate and it may be best to take this from the actual component. At this end of the box there is very little room for the ferrite rod and VC1 and careful siting is essential.

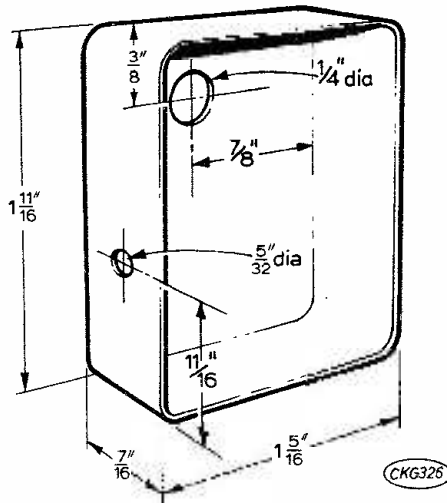

Fig. 3: The holes necessary in the plastic snuff box which is used for the case.

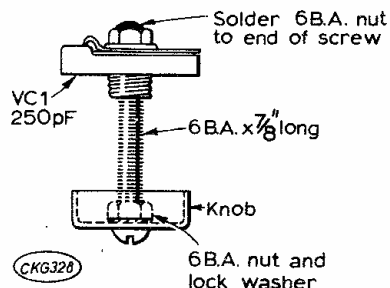

Fig. 4: The modification to the compression trimmer to make it into a variable capacitor.

The tuning capacitor is small 250pF compression trimmer which has to be modified as shown in Fig. 4. The screw supplied should be removed and replaced by a 7/8 in. 6BA screw fitted from the other end. The knob should be held near the head as shown and, after assembly in the box, this should be secured by soldering a nut to the end, ensuring that the special washer is fitted. This trimmer capacitor has rather long solder tags and these should be cut off, leaving just enough to solder to.

The earpiece socket is a 2.5mm type and this has to be adapted as shown in Fig. 5. It must be fitted with a switch but this will be of the break type. For our purposes we need the switch to *make* when the earpiece is inserted and the contact should be modified as shown using fine-nosed pliers.

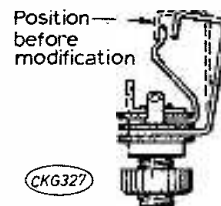

Fig. 5: The 2.5mm jack socket has to be modified to make it switch on when the plug is inserted.

The component layout is shown in Fig. 6. The easiest method is first to mount the wires and R2 directly onto the small socket and then fit this into the case. The components are 'floating' and this will provide an anchoring point. The output lead of the i.c. should be soldered to R2 and the input lead should be run to one connector of VC1. Lengths of wire should be left for the final connection to the mercury cell. These should be soldered directly to it;

To underside
of cell

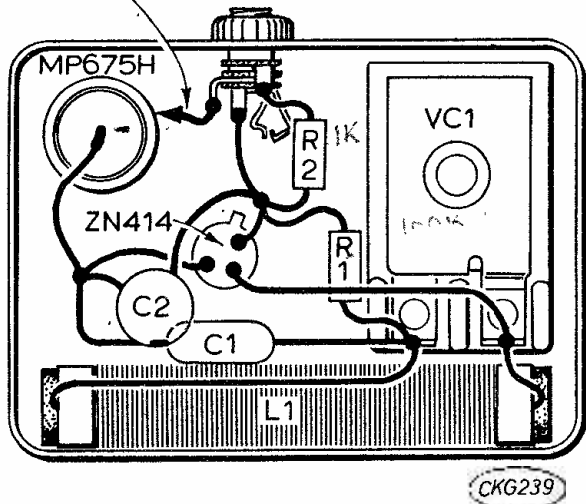
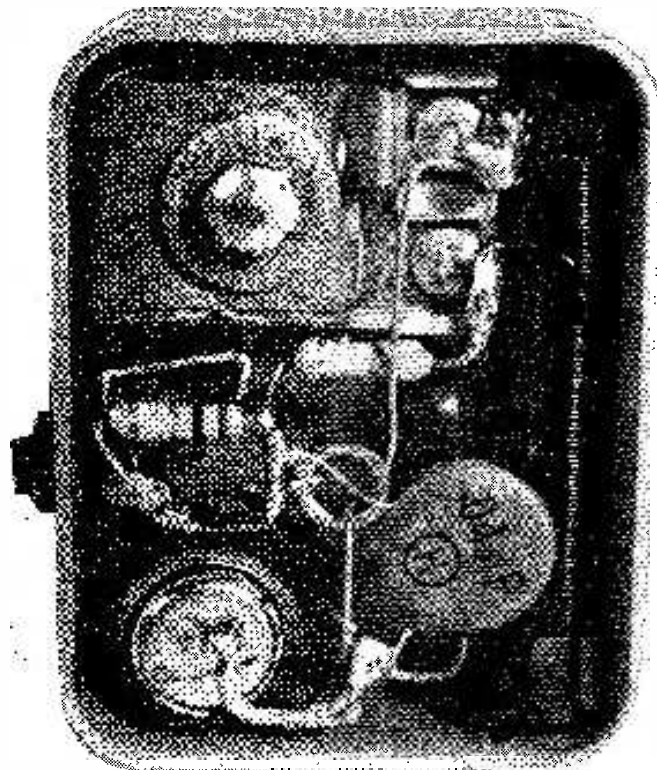
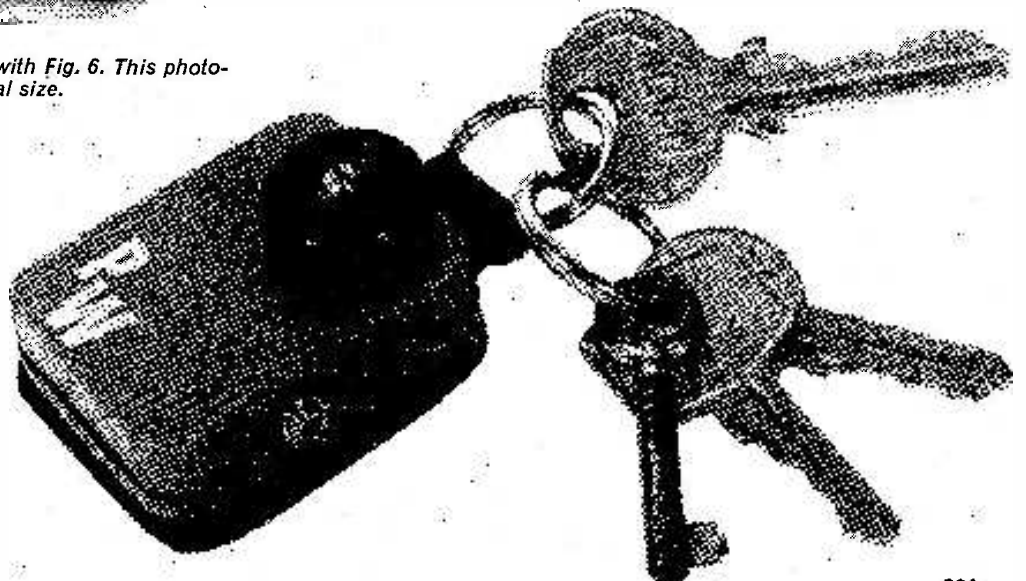

Fig. 6: The components layout. Note that C2 and R2 are left accessible to allow for later experimentation.



An inside shot of the prototype, compare this with Fig. 6. This photograph is of course much larger than actual size.

Being so small, the Mighty Midget lends itself to several types of gimmick. One idea is shown on the right, that of gluing the finished radio to the fob of a key ring.



The Mighty Midget shown full size. We don't claim that this is the smallest radio ever described, but it must be a contender being under one cubic inch in volume!



note that the positive connection is the main body.

Great care should be taken when making this joint as mercury cells can quickly be destroyed if they are overheated. The solder joint must be made as fast as possible and, after it has solidified, the cell should be cooled as quickly as possible—wrapping it in a damp cloth is one way. The author has never destroyed a transistor by soldering but several mercury cells have been ruined, this is only mentioned to emphasise the great care that is needed in this operation.

Ideally a metal lid should not be used but in practice it hardly affects the circuit and, since it forms a neat back, may be used. It should not be connected electrically to any part of the circuit. A small 'nick' will be needed in the lid to prevent it interfering with the earpiece holding nut.

There is of course no lining up and the radio should work immediately upon switching on. It is worthwhile having a look to see that the earpiece on-off switch is operating properly in situ.

The radio is not as directional as most t.r.f.'s and is similar to a superhet; this is on account of the very efficient a.g.c. action; it can certainly be operated from a breast pocket.

The small size, of course, enables lots of gimmicks to be tried. One photograph shows that it can be mounted on a key ring fob.

Few problems should be experienced with this circuit but remember that the i.c. is a delicate device and should be treated carefully—especially while soldering. ■