

5 V-Modulator

TDA 5664

Preliminary Data

Bipolar IC

Function

Monolithic integrated circuit for use as a modulator in the 30 to 860 MHz range.

Application

Video recorders, cable converters, cable TV head stations, remodulators, video generators, video security systems, and personal computers.

Features

- Sync level clamping of video input signal
- Clipping of peak white value
- Continuous adjustment of modulation depth for positive or negative values
- Balanced mixer output with separate ground connection
- Balanced RF oscillator with separate ground connection
- Low spurious radiation
- High stability of the RF oscillator frequency
- High stability of the FM sound oscillator
- Internal reference voltage
- 5 V supply voltage

Type	Ordering Code	Package
TDA 5664	Q67000-A8261	P-DIP-14
TDA 5664-X	Q67000-A8265	P-DSO-14

Circuit Description

Via pin 13 the sound signal is capacitively coupled to the AF input of the sound input amplifier. An external circuitry sets the preemphasis. At the output of the sound section the FM-modulated sound signal is added to the video signal and mixed with the oscillator signal in the RF mixer. A parallel resonant circuit is connected to the sound carrier oscillator at pins 1 and 14.

The video signal with a negative synchronous level is capacitively coupled to pin 8. An internal clamping circuit is referenced to the synchronizing level. When the video voltage V_{VSS} exceeds 1 V, the peak white value is clipped. The RF carrier switches from negative to positive video modulation, when pin 9 is connected to ground. By varying the value of resistance R at pin 9 between $\infty \dots 0 \Omega$ the modulation depth can be increased from 80 % to 100 % when the modulation is negative and decreased from 100 % to 80 % when the modulation is positive.

The amplifier of the RF oscillator is connected to pins 2–6. The oscillator operates as a symmetrical Colpitts circuit. The capacitive reactance for the resonance frequency should be $X_c = 70 \Omega$ between pin 2 and 3 and 5 and 6 and $X_c = 26 \Omega$ between pins 3,5. The oscillator chip ground, pin 4, should be connected to ground at the resonant circuit shielding point. An external oscillator signal can be injected inductively or capacitively via pins 2 and 6. The layout of the PCB should be such as to provide a optimum shielding attenuation between the oscillator pins 2–6 and modulator output pins 10–12 of approximately 80 dB.

For optimal residual carrier suppression, the symmetrical mixer outputs at pins 10–12 should be connected to a matched balanced-to-unbalanced broadband transformer, e.g. a Guanella transformer with good phase precision at 0° and 180° . The transmission loss should be less than 3 dB. In addition a LC low pass filter combination is required at the output. The cut-off frequency of the LC low pass filter combination must exceed the maximum operating frequency.

If the application circuit 1 is used, the RF voltage at the signal output has to be multiplied by a factor of 1.5 in respect of changing from a balanced (300Ω) to an unbalanced impedance (75Ω). The loss of the output transformer is calculated for 0 dB.

Block Diagram

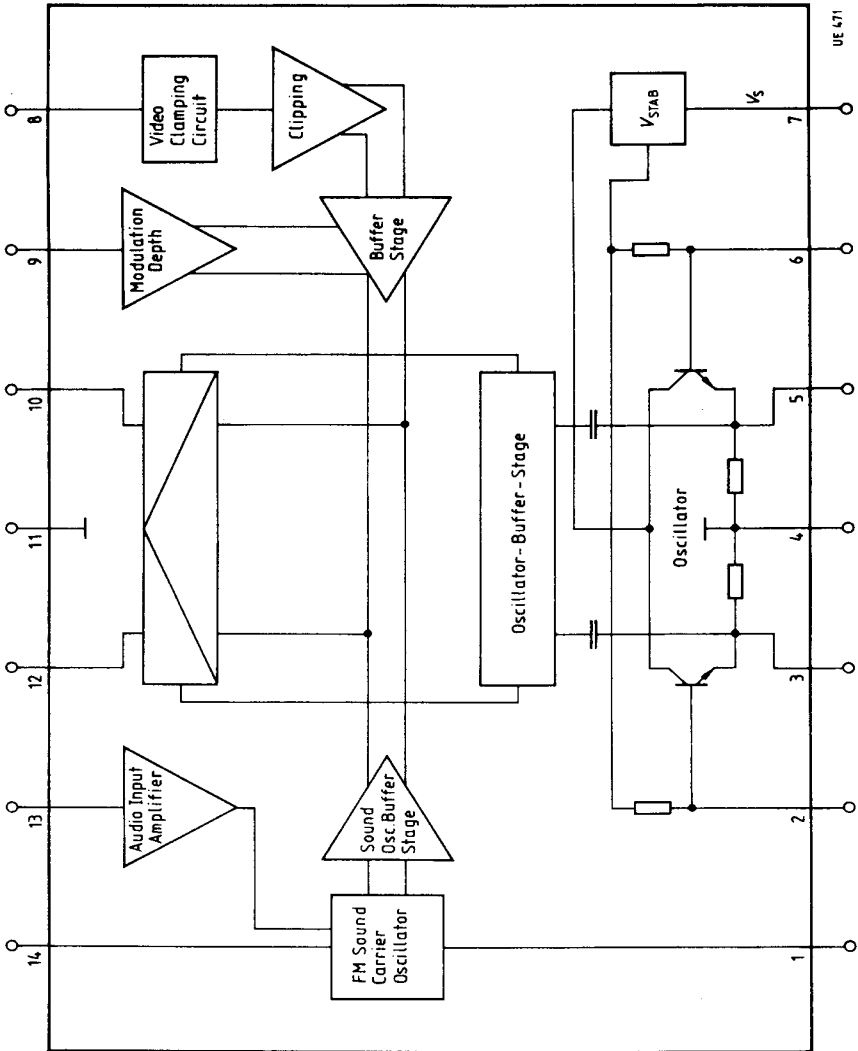

Pin Definitions and Functions

Pin No.	Function	Definition
1	5.5 MHz	Sound carrier oscillator; balanced inputs for tank circuit
2	OSC-Coupling 1	Balanced RF oscillator coupling point
3	OSC-Output 1	Balanced RF output
4	Ground OSC	Oscillator ground
5	OSC-Output 2	Balanced RF output
6	OSC-Coupling 2	Balanced RF oscillator coupling point
7	V_s	Supply voltage
8	Video	Video input with clamping
9	Modulation	Modulation type switch for pos. and neg. modulation and adjustment of modulation depth
10	Output 2	Balanced RF output
11	Ground	Signal and DC ground
12	Output 1	Balanced RF output with opposite phase to pin 10
13	Audio	AF input for FM modulation
14	5.5 MHz	Sound carrier oscillator; balanced inputs for tank circuit

Absolute Maximum Ratings $T_A = 25\text{ °C}$

Parameter	Symbol	Limit Values		Unit	Remarks
		min.	max.		
Supply voltage	V_S	- 0.3	7.5	V	
Current at pin 13	V_1	1	4	V	
Current at pin 8	V_{8PP}		1.5	V	only via $C_{max} = 1\ \mu\text{F}$
Current at pin 9	V_9	- 0.3	1.4	V	
Current at pin 10	V_{10}		6	V	
Current at pin 12	V_{12}		6	V	

According to the application circuit 1, only the provided circuitry can be connected to pins 1, 2, 3, 5, 6 and 14.

Junction temperature	T_j		150	°C	
Storage temperature	T_{stg}	- 40	125	°C	
Thermal resistance	$R_{Th SA}$		83	k/W	

Operating Range

Supply voltage	V_S	4.5	5.5	V	
Video input frequency	f_{vid}	0	6	MHz	
Audio input frequency	f_{AF}	0	20	kHz	
Output frequency	f_o	30	860	MHz	depending on the oscillator circuitry at pins 2 – 6
Ambient temperature	T_A	0	70	°C	
Sound oscillator	f_{osc}	4	7	MHz	

Characteristics $V_S = 5\text{ V}$; $T_A = 25\text{ }^\circ\text{C}$

Parameter	Symbol	Limit Values			Unit	Test Condition	Test Circuit
		min.	typ.	max.			
Current consumption	I_7	15	21	29	mA		
Current consumption	I_{10+12}	1.6	2.2	2.8	mA		1
Oscillator frequency range	f_{osc}	30		860	MHz	external circuitry adjusted to frequency	1
Switch-on, warm-up drift of oscillator frequency	Δf_{osc}	0 0	-50 -200	-500 -500	kHz kHz	Ch 30 Ch 40 <i>TC</i> value of capacitor in osc. circuit is 0; drift is referenced only to self-heating of the IC. $t = 0.5\text{--}10\text{ s}$; $T_A = \text{const.}$	1 1
Frequency drift as function of V_S	$-\Delta f_{osc}$	-120		120	kHz	$V_S = 4.5\text{--}5.5\text{ V}$ $T_A = \text{const.}$ Ch 40	1
Video input voltage at pin 8	V_8	0	1	1.4	V_{pp}	at coupling capacitor $C \leq 1\text{ }\mu\text{F}$ $I_{Leak} \leq \pm 0.3\text{ }\mu\text{A}$	2
Modulation depth	$m_{D/N}$ $m_{D/P}$	70 70	80 80	90 90	% %	neg. mod. pos.mod. Pin 9 at ground $V_{vid} = 1\text{ }V_{pp}$	2
Output impedance	Z_{10} ; Z_{12}	8			$k\Omega$	static	3
RF output voltage	$V_{O\text{ rms}}$	2.5	4	5.5	mV	Ch 40; Pin 9 open	1
Output capacitance	$C_{10} = C_{12}$	0.5	1	2.0	pF		
RF output phase	$\alpha_{10,12}$	140	180	220	deg.		
RF output voltage deviation	ΔV_Q	0		1.5	dB	$f = 543.25\text{--}623.25\text{ MHz}$ $\Delta f = 80\text{ MHz}$ Ch 30 ... Ch 40	1
RF output voltage deviation	ΔV_Q	0		1.5	dB	$f = 100\text{--}300\text{ MHz}$	4
RF output voltage deviation	ΔV_Q	0		1.5	dB	$f = 48\text{--}100\text{ MHz}$	4

Characteristics $V_S = 5 \text{ V}; T_A = 25 \text{ }^\circ\text{C}$

Parameter	Symbol	Limit Values			Unit	Test Condition	Test Circuit
		min.	typ.	max.			
Intermodulation ratio	a_{IMA}	53	58		dB	$f_p + 1.07 \text{ MHz}$	5
Harmonic wave ratio	a_O	40	46		dB	$f_p + 8.8 \text{ MHz}$ without vid.sig.	5
Harmonic wave ratio	a_O	35	58		dB	Unmodulated video and sound carrier, measured with the spectrum analyser as difference between video carrier signal level and	1; diagram 2
Harmonic wave ratio	a_O	42	60		dB		1; diagram 2
Sound carrier range	$a_{P/S}$	10	12.5	15	dB	sideband signal level, $R_p = 10 \text{ k}\Omega$	1; diagram 2
All remaining harmonic waves	a_{VC}	15			dB	Multiple of fundamental wave of picture carrier, without video signal, measured with spectrum analyser; $f_{VC} = 543.25\text{--}623.25 \text{ MHz}$	1
Amplitude response of video signal	a_V			1.5	dB	$V_{vid} = 1V_{pp}$ with additional modulation $f = 15 \text{ kHz--}5 \text{ MHz}$ sine wave signal between black and white	5
Residual carrier suppression	a_R	26			dB	Ch 30 ... Ch 40	9
Stability of modulation depth	Δm_T		± 3	± 10	%	staircase signal at Video input $\Delta V_{vid} = 1 V_{pp}$; Ch 30 ... Ch 40; $V_S = 5V; T_A = \text{const.}$ $V_S = 4.5\text{--}5.5 V; T_A = \text{const.}$ $\Delta V_{vid} = 1 V_{pp}$	2
	Δm_T		± 1	± 3	%		2

Characteristics $V_S = 5 \text{ V}$; $T_A = 25 \text{ }^\circ\text{C}$

Parameter	Symbol	Limit Values			Unit	Test Condition	Test Circuit
		min.	typ.	max.			
Interference product ratio sound in video	$a_{S/P}$	48	88		dB	FM modulation of sound carrier; Ch 30 ... Ch 40	6
Signal-to-noise in video	$a_{N/P}$	48	90		dB	Unmodulated sound carrier; Ch 30 ... Ch 40	6
Unweighted FM noise level ratio in video sound	$a_{P/S}$	45	50		dB	FuBK – test picture as video signal; $V_{vid} = 1 \text{ V}_{pp}$ Ch 30 ... Ch 40	7
Signal-to-noise in sound	$a_{N/S}$	48	52		dB	Unmodulated sound carrier	7
Differential gain	a_{dif}				%	Measured with test demodulator, video test signals and vector scope $V_{vid} = 1 \text{ V}_{pp}$	1
Differential phase							
Sound oscillator frequency range	$f_{S/OSC}$	4		7	MHz	Unloaded Q factor of resonant circuit $Q_u = 8$ resonance frequency 5.5 MHz	1
Switch-on, warm-up drift of oscillator frequency	$\Delta f_{S/OSC}$		5	15	kHz	$T_A = \text{const.}$; TC value of capacitor in sound oscillator circuit is 0; the drift is only based on self-heating of the IC; $f_{S/OSC} = 5.5 \text{ MHz}$	1
Sound oscillator frequency deviation	$\Delta f_{S/OSC}$		5	15	kHz	$V_S = 4.5\text{--}5.5 \text{ V}$; $f_{S/OSC} = 5.5 \text{ MHz}$; $T_A = \text{const.}$; $Q_u = 8$	1
FM modulation harmonic distortion	THD_{FM}		0.6	1.5	%	$V_{1rms} 634 \text{ mV}$	8
Audio preamplifier input impedance (dynamic)	Z_{13}	15	22	29	k Ω		1
FM sound modulation (static)	$\Delta f_{S/OSC}$	± 350	± 450	± 540	kHz	$\Delta V_{1/2} = V_1 - V_2 = \pm 1 \text{ V}$; $f_{S/OSC} = 5.5 \text{ MHz}$; $Q_u = 8$	1
FM sound modulation (dynamic)	$\Delta f_{S/OSC} / \Delta V_1$	0.7	0.93	1.1	kHz/mV		1

Test Circuit 1 for FM Sound Carrier and Negative Video Modulation

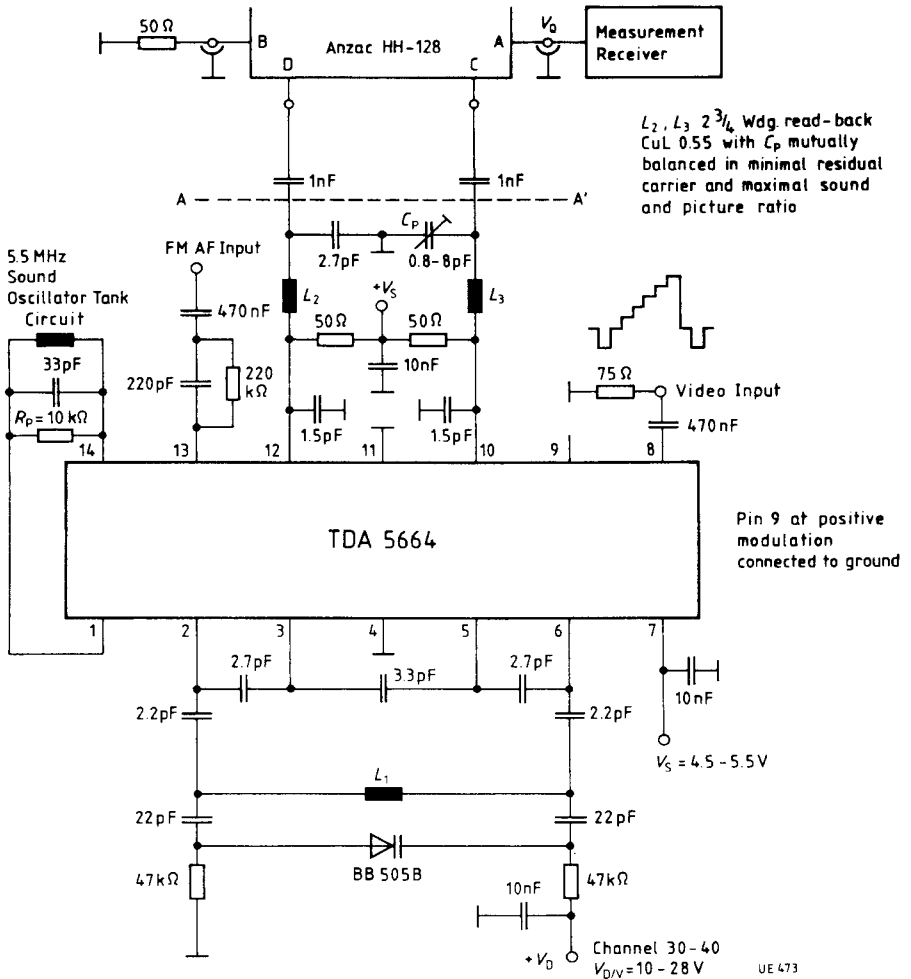

Test Circuit 2

Measuring of the Modulation Depth for Positive and Negative Modulation

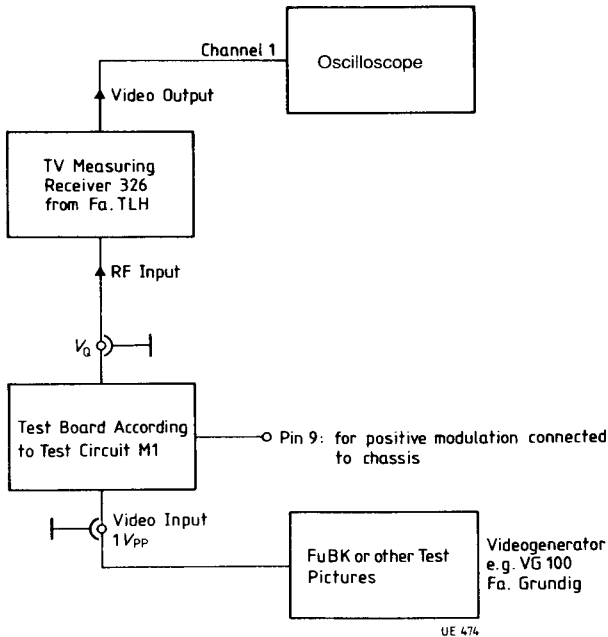

Calibration: A zero reference signal with the TV measuring receiver is given to the video signal. A video signal with $V_{vid} = 1 V_{pp}$ is connected to the video input.

Measurement: 1) Modulation depth $m_{D/N}$ for negative modulation: Pin 9 open, range peak white value – sync level in relation to range zero reference – sync level gives $m_{D/N}$.

2) Modulation depth $m_{D/P}$ for positive modulation. Pin 9 to ground, range peak white value – sync level in relation to range zero reference – peak white value gives $m_{D/P}$.

Test Circuit 3

Measurement of the Static Output Frequency

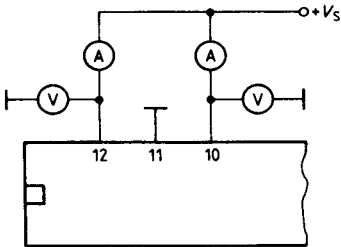

$$Z_{12} = \frac{\Delta V_{12}}{\Delta I_{12}} \quad \text{UE 475}$$

$$Z_{10} = \frac{\Delta V_{10}}{\Delta I_{10}}$$

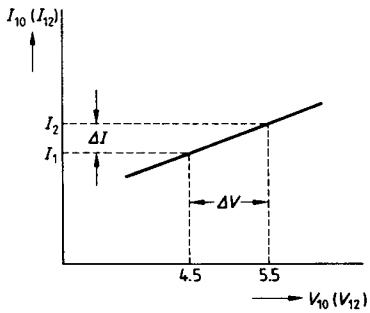

UE 476

Test Circuit 4

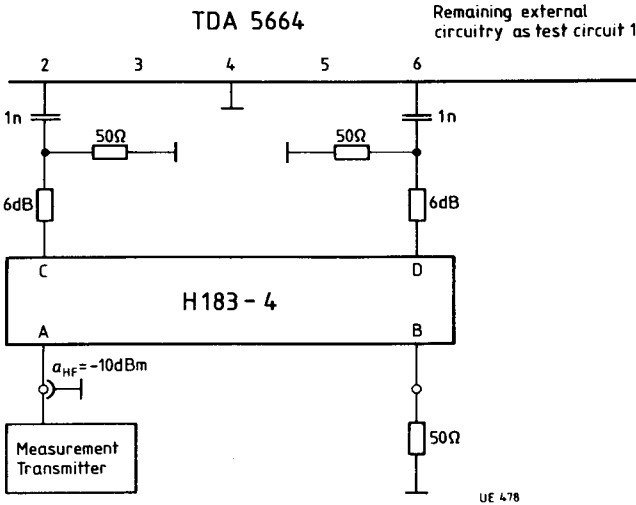
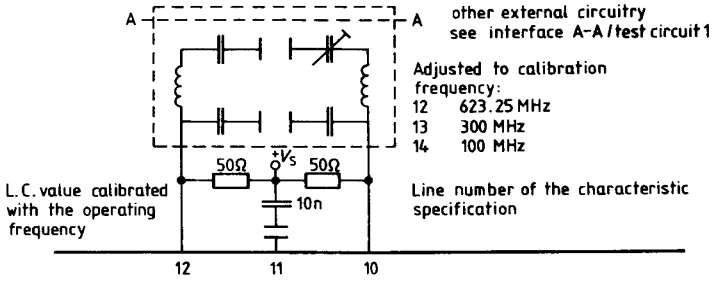

Test Circuit 5

Measurement Configuration to Measure the 1.07 MHz Moires

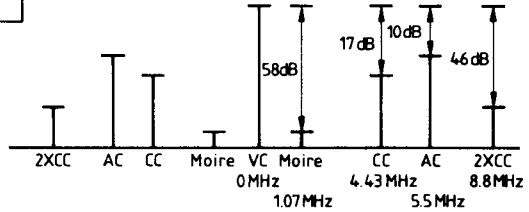
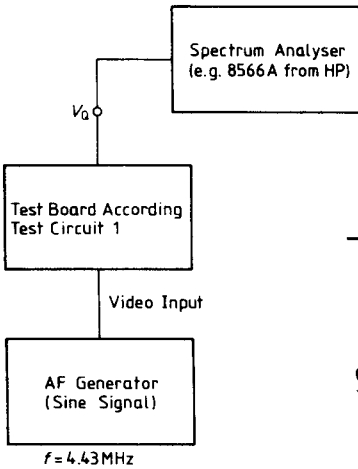

C.C. level lies below the activation point and has been set to provide a ratio of 17dB with respect to the video carrier.
 $f_{VC} = 623.25 \text{ MHz}$

UE 479

Test Circuit 6

Measurement Configuration to Measure the Audio and/or Noise in Video during FM Modulation of the Sound Carrier

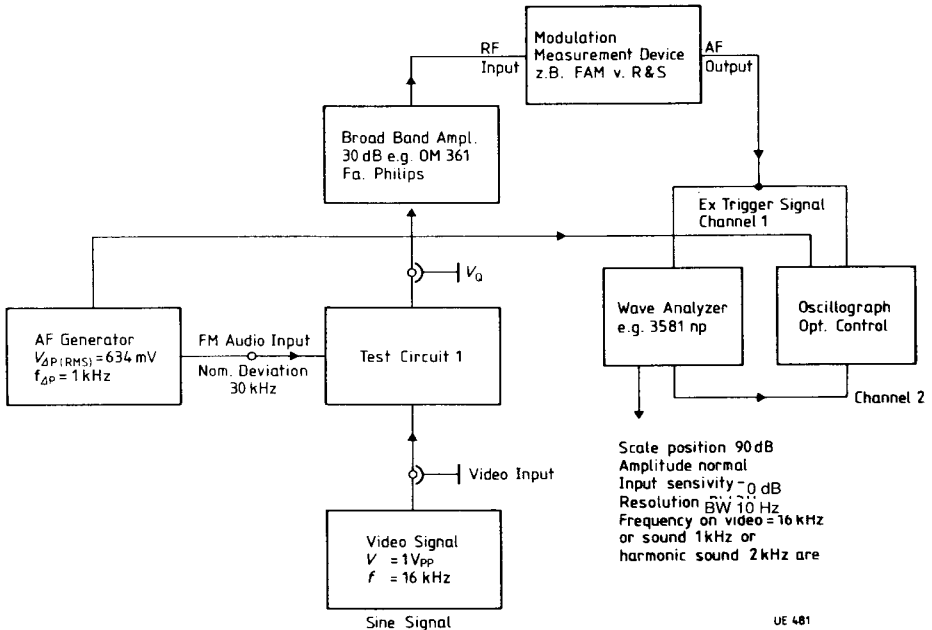

Calibration: AF signals are switched off, video signal is present at video input, modulation measurement device set at AM is adjusted to video carrier; filter: 300 Hz ... 20 kHz; detector: $(P + P)/2$; wave analyzer at video signal level (16 kHz) adjusted and resultant level as reference a_v defined.

1) Measurement of audio interference product ratio in video during FM modulation of the sound carrier: AF signal is connected to FM audio input; modulation measurement device set at AM; filter: 300 Hz ... 20 kHz; detector: $(P + P)/2$; the automatic RF level position of the measurement device is switched off; wave analyzer at video signal level 1 kHz or 2 kHz or 3 kHz adjusted and resultant level is set to a_s . The audio noise ratio in video results from $a_{S/P} = a_s - a_v$ (dB).

2) Measurement of signal-to-noise ratio in video without AM/FM modulation of sound carrier: AF signals are switched off; video signal is switched off; modulation measurement device set at AM; filter: 300 Hz ... 3 kHz; detector: $RMS/\sqrt{2}$; read out in dB to reference level of calibration is $a_{N/P}$.

3) The noise limit of the measurement device is approx. 85 dB.

Test Circuit 7

Measurement Configuration to Measure the Video and/or Noise in Sound

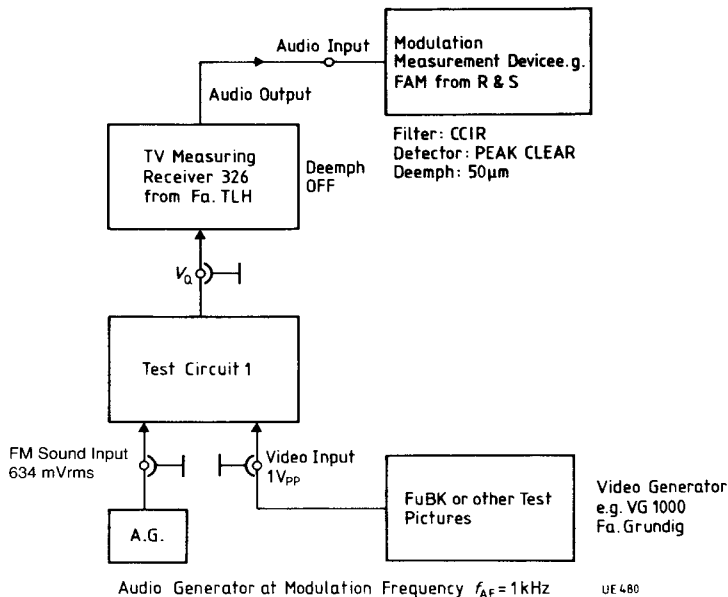

Calibration: A signal of $V_{AM} = 634\text{ mV}_{rms}$ and $f = 1\text{ kHz}$, corresponding to a nominal deviation of 30 kHz, is connected to the audio input, and the demodulated AF reference level at the audio measurement device is defined as 0 dB. No video signal is present.

Measurement: 1) The AF signal is switched off and the FuBK video signal is connected to the video input with $V_{vid} = 1\text{ V}_{pp}$. The audio level in relation to the reference calibration level is measured as ratio $a_{P/S} = 20 \log (V_{video}) / (V_{nom.})$.

2) AF and video signal are switched off. The noise ratio in relation to the AF reference calibration level is measured as signal-to-noise ratio $a_{S/N}$.

Test Circuit 8

Measurement Configuration to Measure the Harmonic Distortion Factor during FM Operation of the Sound Carrier

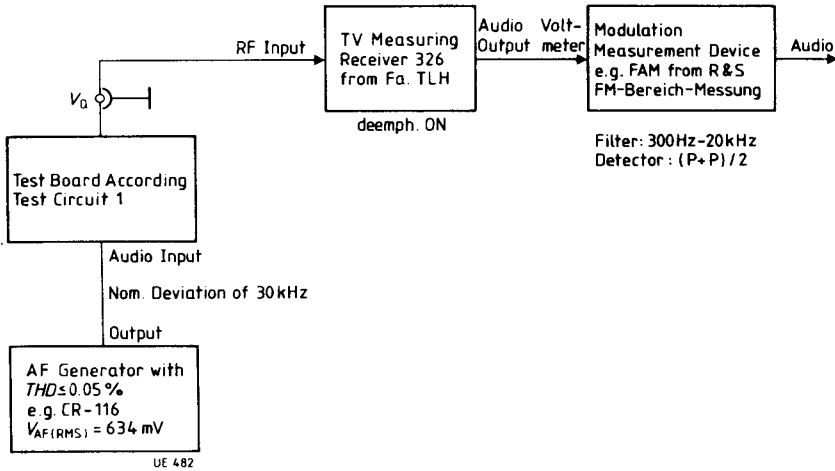

Test Circuit 9

Measurement Configuration to Measure the Residual Carrier Suppression

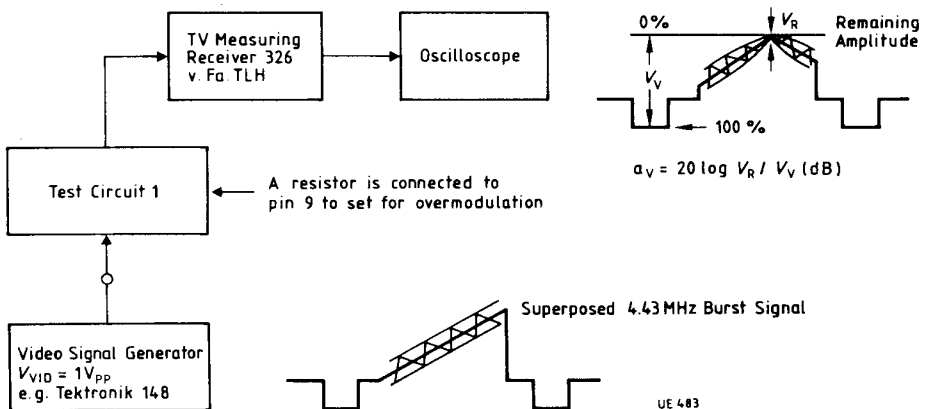

Application Circuit 1

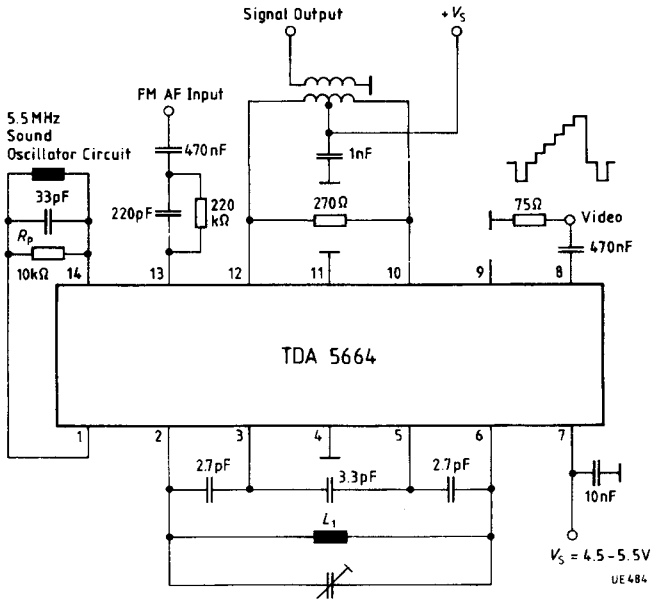

Application Circuit 2

Application with a Very Good Residual Carrier Suppression

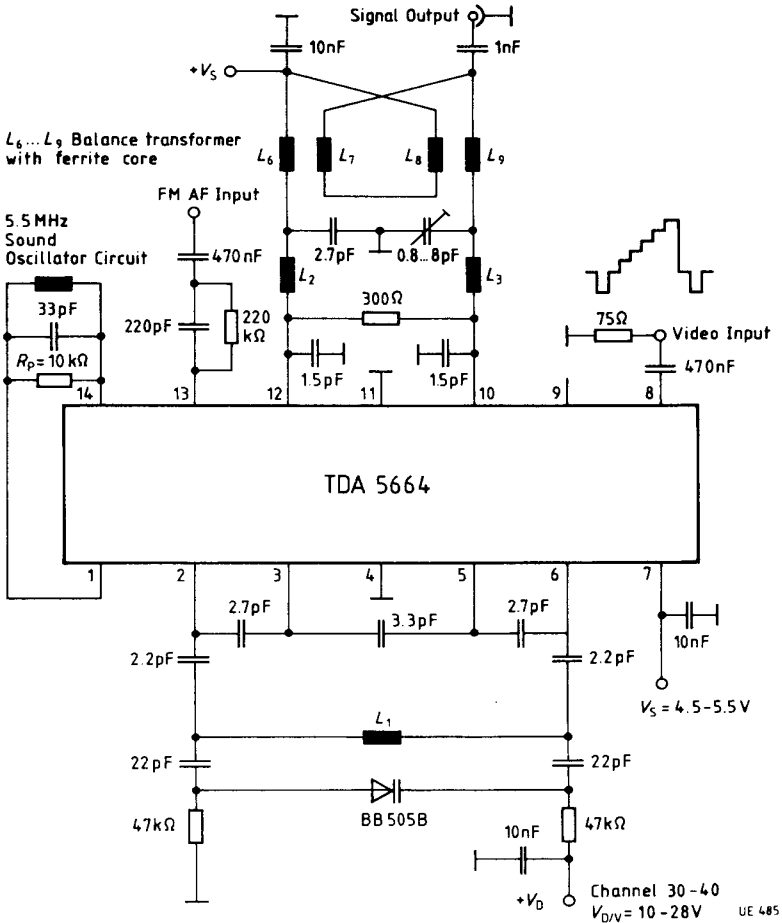

Display of the Frequency Spectrum

- Measured at clamp V_Q with spectrum analyser
- Video and audio unmodulated

