

CD4528BM/CD4528BC Dual Monostable Multivibrator

General Description

The CD4528B is a dual monostable multivibrator. Each device is retriggerable and resettable. Triggering can occur from either the rising or falling edge of an input pulse, resulting in an output pulse over a wide range of widths. Pulse duration and accuracy are determined by external timing components Rx and Cx.

Features

- Wide supply voltage range 3.0V to 18V
- Separate reset available
- Quiescent current = 5.0 nA/package (typ.) at 5.0 V_{DC}
- Diode protection on all inputs
- Triggerable from leading or trailing edge pulse
- Capable of driving two low-power TTL loads or one low-power Schottky TTL load over the rated temperature range

Connection Diagrams

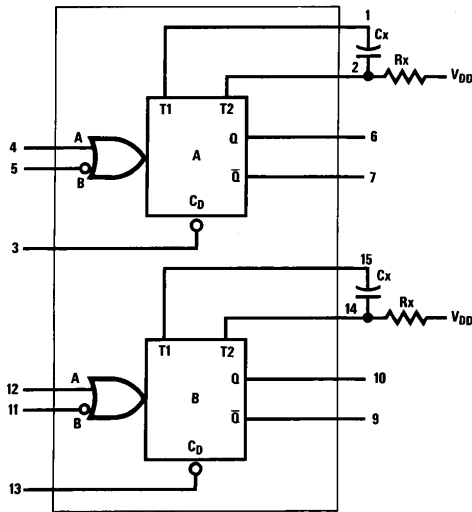

TL/F/5998-1

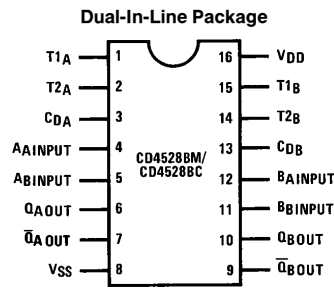

TL/F/5998-2

Top View
Order Number CD4528B

Truth Table

Clear	Inputs		Outputs	
	A	B	Q	Q
L	X	X	L	H
X	H	X	L	H
X	X	L	L	H
H	L	↓	⌋	⌋
H	↑	H	⌋	⌋

- H = High Level
- L = Low Level
- ↑ = Transition from Low to High
- ↓ = Transition from High to Low
- ⌋ = One High Level Pulse
- ⌋ = One Low Level Pulse
- X = Irrelevant

Absolute Maximum Ratings (Notes 1 & 2)

If Military/Aerospace specified devices are required, please contact the National Semiconductor Sales Office/Distributors for availability and specifications.

DC Supply Voltage (V_{DD})	$-0.5 V_{DC}$ to $+18 V_{DC}$
Input Voltage, All Inputs (V_{IN})	$-0.5 V_{DC}$ to $V_{DD} + 0.5 V_{DC}$
Storage Temperature Range (T_S)	-65°C to $+150^{\circ}\text{C}$
Power Dissipation (P_D)	
Dual-In-Line	700 mW
Small Outline	500 mW
Lead Temperature (T_L)	
(Soldering, 10 seconds)	260°C

Recommended Operating Conditions (Note 2)

DC Supply Voltage (V_{DD})	3V to 15V
Input Voltage (V_{IN})	0V to $V_{DD} V_{DC}$
Operating Temperature Range (T_A)	
CD4528BM	-55°C to $+125^{\circ}\text{C}$
CD4528BC	-40°C to $+85^{\circ}\text{C}$

DC Electrical Characteristics CD4528BM (Note 2)

Symbol	Parameter	Conditions	-55°C		$+25^{\circ}\text{C}$			$+125^{\circ}\text{C}$		Units
			Min	Max	Min	Typ	Max	Min	Max	
I_{DD}	Quiescent Device Current	$V_{DD} = 5V$		5	0.005		5		150	μA
		$V_{DD} = 10V$		10	0.010		10		300	μA
		$V_{DD} = 15V$		20	0.015		20		600	μA
V_{OL}	Low Level Output Voltage	$V_{DD} = 5V$		0.05			0.05		0.05	V
		$V_{DD} = 10V$		0.05			0.05		0.05	V
		$V_{DD} = 15V$		0.05			0.05		0.05	V
V_{OH}	High Level Output Voltage	$V_{DD} = 5V$	4.95		4.95	5.0		4.95		V
		$V_{DD} = 10V$	9.95		9.95	10.0		9.95		V
		$V_{DD} = 15V$	14.95		14.95	15.0		14.95		V
V_{IL}	Low Level Input Voltage	$V_{DD} = 5V, V_O = 0.5V$ or $4.5V$		1.5		2.25	1.5		1.5	V
		$V_{DD} = 10V, V_O = 1V$ or $9V$		3.0		4.50	3.0		3.0	V
		$V_{DD} = 15V, V_O = 1.5V$ or $13.5V$		4.0		6.75	4.0		4.0	V
V_{IH}	High Level Input Voltage	$V_{DD} = 5V, V_O = 0.5V$ or $4.5V$	3.5		3.5	2.75		3.5		V
		$V_{DD} = 10V, V_O = 1V$ or $9V$	7.0		7.0	5.50		7.0		V
		$V_{DD} = 15V, V_O = 1.5V$ or $13.5V$	11.0		11.0	8.25		11.0		V
I_{OL}	Low Level Output Current (Note 3)	$V_{DD} = 5V, V_O = 0.4V$	0.64		0.51	0.88		0.36		mA
		$V_{DD} = 10V, V_O = 0.5V$	1.6		1.3	2.25		0.9		mA
		$V_{DD} = 15V, V_O = 1.5V$	4.2		3.4	8.8		2.4		mA
I_{OH}	High Level Output Current (Note 3)	$V_{DD} = 5V, V_O = 4.6V$	-0.25		-0.2	-0.36		-0.14		mA
		$V_{DD} = 10V, V_O = 9.5V$	-0.62		-0.5	-0.9		-0.35		mA
		$V_{DD} = 15V, V_O = 13.5V$	-1.8		-1.5	-3.5		-1.1		mA
I_{IN}	Input Current	$V_{DD} = 15V, V_{IN} = 0V$		-0.1		-10^{-5}	-0.1		-1.0	μA
		$V_{DD} = 15V, V_{IN} = 15V$		0.1		10^{-5}	0.1		1.0	μA

Note 1: "Absolute Maximum Ratings" are those values beyond which the safety of the device cannot be guaranteed. Except for "Operating Temperature Range", they are not meant to imply that the devices should be operated at these limits. The table of "Electrical Characteristics" provides conditions for actual device operation.

Note 2: $V_{SS} = 0V$ unless otherwise specified.

Note 3: I_{OH} and I_{OL} are tested one output at a time.

DC Electrical Characteristics CD4528BC (Note 2)

Symbol	Parameter	Conditions	-40°C		+25°C			+85°C		Units
			Min	Max	Min	Typ	Max	Min	Max	
I _{DD}	Quiescent Device Current	V _{DD} = 5V		20		0.005	20		150	μA
		V _{DD} = 10V		40		0.010	40		300	μA
		V _{DD} = 15V		80		0.015	80		600	μA
V _{OL}	Low Level Output Voltage	V _{DD} = 5V		0.05			0.05		0.05	V
		V _{DD} = 10V		0.05			0.05		0.05	V
		V _{DD} = 15V		0.05			0.05		0.05	V
V _{OH}	High Level Output Voltage	V _{DD} = 5V	4.95		4.95	5.0		4.95		V
		V _{DD} = 10V	9.95		9.95	10.0		9.95		V
		V _{DD} = 15V	14.95		14.95	15.0		14.95		V
V _{IL}	Low Level Input Voltage	V _{DD} = 5V, V _O = 0.5V or 4.5V		1.5		2.25	1.5		1.5	V
		V _{DD} = 10V, V _O = 1V or 9V		3.0		4.50	3.0		3.0	V
		V _{DD} = 15V, V _O = 1.5V or 13.5V		4.0		6.75	4.0		4.0	V
V _{IH}	High Level Input Voltage	V _{DD} = 5V, V _O = 0.5V or 4.5V	3.5		3.5	2.75		3.5		V
		V _{DD} = 10V, V _O = 1V or 9V	7.0		7.0	5.50		7.0		V
		V _{DD} = 15V, V _O = 1.5V or 13.5V	11.0		11.0	8.25		11.0		V
I _{OL}	Low Level Output Current (Note 3)	V _{DD} = 5V, V _O = 0.4V	0.52		0.44	0.88		0.36		mA
		V _{DD} = 10V, V _O = 0.5V	1.3		1.1	2.25		0.9		mA
		V _{DD} = 15V, V _O = 1.5V	3.6		3.0	8.8		2.4		mA
I _{OH}	High Level Output Current (Note 3)	V _{DD} = 5V, V _O = 4.6V	-0.2		-0.16	-0.36		-0.12		mA
		V _{DD} = 10V, V _O = 9.5V	-0.5		-0.4	-0.9		-0.3		mA
		V _{DD} = 15V, V _O = 13.5V	-1.4		-1.2	-3.5		-1.0		mA
I _{IN}	Input Current	V _{DD} = 15V, V _{IN} = 0V		-0.3		-10 ⁻⁵	-0.3		-1.0	μA
		V _{DD} = 15V, V _{IN} = 15V		0.3		10 ⁻⁵	0.3		1.0	μA

Note 1: "Absolute Maximum Ratings" are those values beyond which the safety of the device cannot be guaranteed. Except for "Operating Temperature Range", they are not meant to imply that the devices should be operated at these limits. The table of "Electrical Characteristics" provides conditions for actual device operation.

Note 2: V_{SS} = 0V unless otherwise specified.

Note 3: I_{OH} and I_{OL} are tested one output at a time.

AC Electrical Characteristics* CD4528BM

$T_A = 25^\circ\text{C}$, $C_L = 50\text{ pF}$, $R_L = 200\text{ k}\Omega$, Input $t_r = t_f = 20\text{ ns}$, unless otherwise specified

Parameter	Conditions	Min	Typ	Max	Units
Output Rise Time	$t_r = (3.0\text{ ns/pF}) C_L + 30\text{ ns}$, $V_{DD} = 5.0\text{V}$		180	400	ns
	$t_r = (1.5\text{ ns/pF}) C_L + 15\text{ ns}$, $V_{DD} = 10.0\text{V}$		90	200	ns
	$t_r = (1.1\text{ ns/pF}) C_L + 10\text{ ns}$, $V_{DD} = 15.0\text{V}$		65	160	ns
Output Fall Time	$t_f = (1.5\text{ ns/pF}) C_L + 25\text{ ns}$, $V_{DD} = 5.0\text{V}$		100	200	ns
	$t_f = (0.75\text{ ns/pF}) C_L + 12.5\text{ ns}$, $V_{DD} = 10\text{V}$		50	100	ns
	$t_f = (0.55\text{ ns/pF}) C_L + 9.5\text{ ns}$, $V_{DD} = 15.0\text{V}$		35	80	ns
Turn-Off, Turn-On Delay A or B to Q or \bar{Q} $C_x = 15\text{ pF}$, $R_x = 5.0\text{ k}\Omega$	t_{PLH} , $t_{PHL} = (1.7\text{ ns/pF}) C_L + 240\text{ ns}$, $V_{DD} = 5.0\text{V}$		230	500	ns
	t_{PLH} , $t_{PHL} = (0.66\text{ ns/pF}) C_L + 8\text{ ns}$, $V_{DD} = 10.0\text{V}$		100	250	ns
	t_{PLH} , $t_{PHL} = (0.5\text{ ns/pF}) C_L + 65\text{ ns}$, $V_{DD} = 15.0\text{V}$		65	150	ns
Turn-Off, Turn-On Delay A or B to Q or \bar{Q} $C_x = 100\text{ pF}$, $R_x = 10\text{ k}\Omega$	t_{PLH} , $t_{PHL} = (1.7\text{ ns/pF}) C_L + 620\text{ ns}$, $V_{DD} = 5.0\text{V}$		230	500	ns
	t_{PLH} , $t_{PHL} = (0.66\text{ ns/pF}) C_L + 257\text{ ns}$, $V_{DD} = 10.0\text{V}$		100	250	ns
	t_{PLH} , $t_{PHL} = (0.5\text{ ns/pF}) C_L + 185\text{ ns}$, $V_{DD} = 15.0\text{V}$		65	150	ns
Minimum Input Pulse Width A or B $C_x = 15\text{ pF}$, $R_x = 5.0\text{ k}\Omega$	$V_{DD} = 5.0\text{V}$		60	150	ns
	$V_{DD} = 10.0\text{V}$		20	50	ns
	$V_{DD} = 15\text{V}$		20	50	ns
$C_x = 1000\text{ pF}$, $R_x = 10\text{ k}\Omega$	$V_{DD} = 5.0\text{V}$		60	150	ns
	$V_{DD} = 10.0\text{V}$		20	50	ns
	$V_{DD} = 15.0\text{V}$		20	50	ns
Output Pulse Width Q or \bar{Q} For $C_x < 0.01\text{ }\mu\text{F}$ (See Graph for Appropriate V_{DD} Level) $C_x = 15\text{ pF}$, $R_x = 5.0\text{ k}\Omega$	$V_{DD} = 5.0\text{V}$		550		ns
	$V_{DD} = 10.0\text{V}$		350		ns
	$V_{DD} = 15.0\text{V}$		300		ns
For $C_x > 0.01\text{ }\mu\text{F}$ Use $PW_{out} = 0.2 R_x C_x \ln [V_{DD} - V_{SS}]$ $C_x = 10,000\text{ pF}$, $R_x = 10\text{ k}\Omega$	$V_{DD} = 5.0\text{V}$	15	29	45	μs
	$V_{DD} = 10.0\text{V}$	10	37	90	μs
	$V_{DD} = 15.0\text{V}$	15	42	95	μs
Pulse Width Match between Circuits in the Same Package $C_x = 10,000\text{ pF}$, $R_x = 10\text{ k}\Omega$	$V_{DD} = 5.0\text{V}$		6	25	%
	$V_{DD} = 10.0\text{V}$		8	35	%
	$V_{DD} = 15.0\text{V}$		8	35	%
Reset Propagation Delay, t_{PLH} , t_{PHL} $C_x = 15\text{ pF}$, $R_x = 5.0\text{ k}\Omega$	$V_{DD} = 5.0\text{V}$		325	600	ns
	$V_{DD} = 10.0\text{V}$		90	225	ns
	$V_{DD} = 15.0\text{V}$		60	170	ns
$C_x = 1000\text{ pF}$, $R_x = 10\text{ k}\Omega$	$V_{DD} = 5.0\text{V}$		7.0		μs
	$V_{DD} = 10.0\text{V}$		6.7		μs
	$V_{DD} = 15.0\text{V}$		6.7		μs
Minimum Retrigger Time $C_x = 15\text{ pF}$, $R_x = 5.0\text{ k}\Omega$ $C_x = 1000\text{ pF}$, $R_x = 10\text{ k}\Omega$	$V_{DD} = 5.0\text{V}$		0		ns
	$V_{DD} = 10.0\text{V}$		0		ns
	$V_{DD} = 15.0\text{V}$		0		ns
	$V_{DD} = 5.0\text{V}$		0		ns
	$V_{DD} = 10.0\text{V}$		0		ns
	$V_{DD} = 15.0\text{V}$		0		ns

*AC parameters are guaranteed by DC correlated testing.

Logic Diagrams (1/2 of Device Shown)

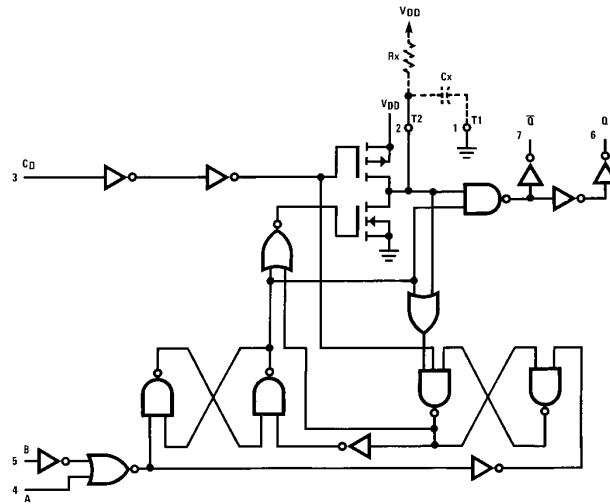

Note: Externally ground pins 1 and 15 to pin 8.

TL/F/5998-3

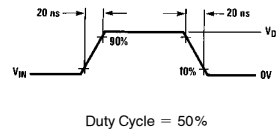
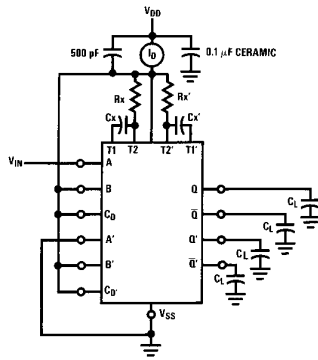

TL/F/5998-10

TL/F/5998-4

FIGURE 1. Power Dissipation Test Circuit and Waveforms

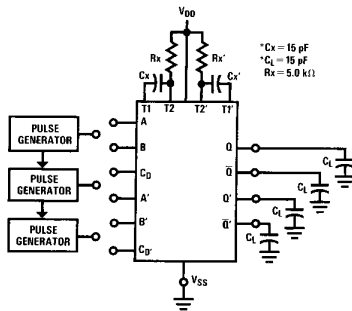

TL/F/5998-5

FIGURE 2. AC Test Circuit

Input Connections

Characteristics	C_D	A	B
t_{PLH} , t_{PHL} , t_r , t_f , PW_{out} , PW_{in}	V_{DD}	PG1	V_{DD}
t_{PLH} , t_{PHL} , t_r , t_f , PW_{out} , PW_{in}	V_{DD}	V_{SS}	PG2
$t_{PLH(R)}$, $t_{PHL(R)}$, PW_{in}	PG3	PG1	PG2

*Includes capacitance of probes, wiring, and fixture parasitic.

Note: AC test waveforms for PG1, PG2, and PG3 on next page.

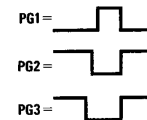

TL/F/5998-6

Logic Diagrams (1/2 of Device Shown) (Continued)

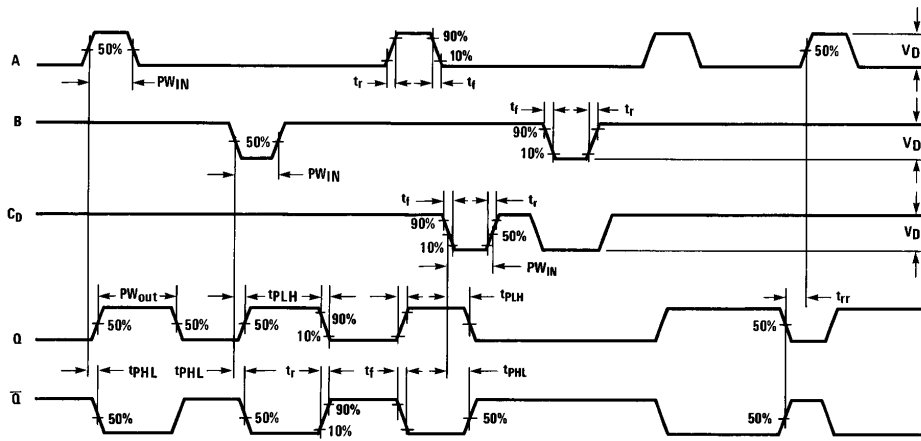

FIGURE 3. AC Test Waveforms

TL/F/5998-7

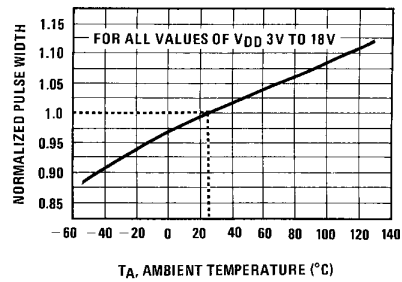

FIGURE 4. Normalized Pulse Width vs Temperature

TL/F/5998-8

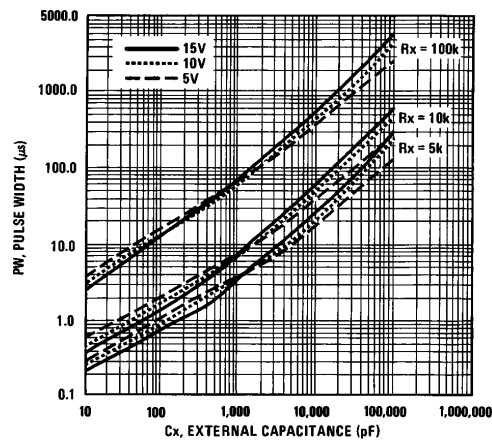
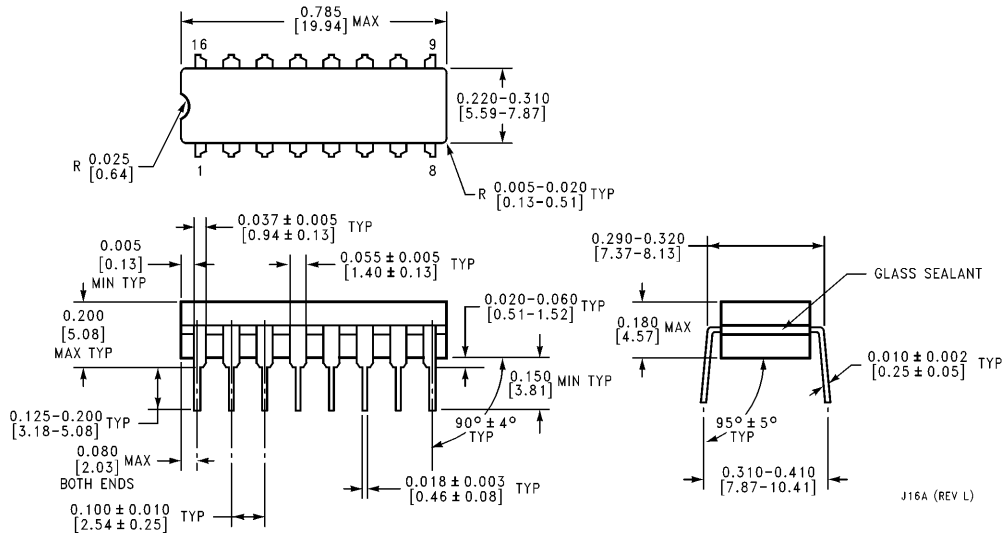

FIGURE 5. Pulse Width vs Cx

TL/F/5998-9

Physical Dimensions inches (millimeters)



Ceramic Dual-In-Line Package (J)
Order Number CD4528BMJ or CD4528BCJ
NS Package Number J16A

J16A (REV L)

Physical Dimensions inches (millimeters) (Continued)

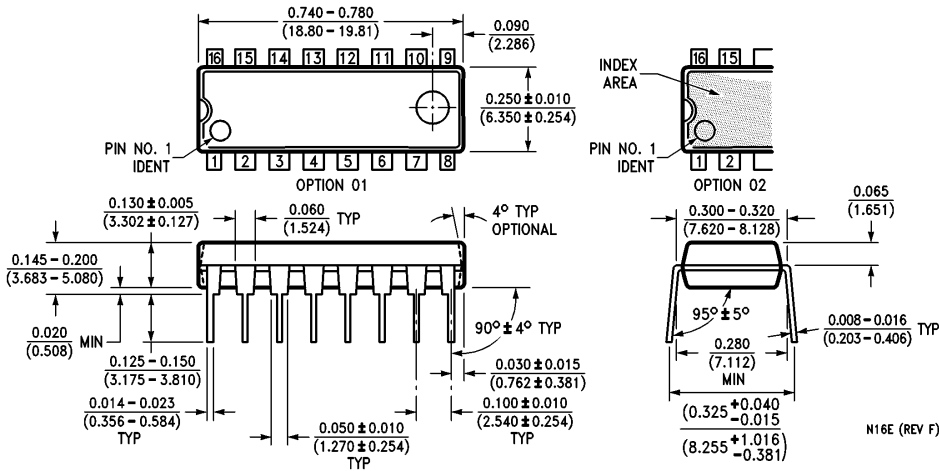

Molded Dual-In-Line Package (N)
Order Number CD4528BMN or CD4528BCN
NS Package Number N16E

LIFE SUPPORT POLICY

NATIONAL'S PRODUCTS ARE NOT AUTHORIZED FOR USE AS CRITICAL COMPONENTS IN LIFE SUPPORT DEVICES OR SYSTEMS WITHOUT THE EXPRESS WRITTEN APPROVAL OF THE PRESIDENT OF NATIONAL SEMICONDUCTOR CORPORATION. As used herein:

1. Life support devices or systems are devices or systems which, (a) are intended for surgical implant into the body, or (b) support or sustain life, and whose failure to perform, when properly used in accordance with instructions for use provided in the labeling, can be reasonably expected to result in a significant injury to the user.
2. A critical component is any component of a life support device or system whose failure to perform can be reasonably expected to cause the failure of the life support device or system, or to affect its safety or effectiveness.



National Semiconductor Corporation
 1111 West Bardin Road
 Arlington, TX 76017
 Tel: 1(800) 272-9959
 Fax: 1(800) 737-7018

National Semiconductor Europe
 Fax: (+49) 0-180-530 85 86
 Email: cnjwge@tevm2.nsc.com
 Deutsch Tel: (+49) 0-180-530 85 85
 English Tel: (+49) 0-180-532 78 32
 Français Tel: (+49) 0-180-532 93 58
 Italiano Tel: (+49) 0-180-534 16 80

National Semiconductor Hong Kong Ltd.
 19th Floor, Straight Block,
 Ocean Centre, 5 Canton Rd.
 Tsimshatsui, Kowloon
 Hong Kong
 Tel: (852) 2737-1600
 Fax: (852) 2736-9960

National Semiconductor Japan Ltd.
 Tel: 81-043-299-2309
 Fax: 81-043-299-2408

National does not assume any responsibility for use of any circuitry described, no circuit patent licenses are implied and National reserves the right at any time without notice to change said circuitry and specifications.

This datasheet has been downloaded from:

www.DatasheetCatalog.com

Datasheets for electronic components.

National Semiconductor was acquired by Texas Instruments.

http://www.ti.com/corp/docs/investor_relations/pr_09_23_2011_national_semiconductor.html

This file is the datasheet for the following electronic components:

CD4528BMN - <http://www.ti.com/product/cd4528bmn?HQS=TI-null-null-dscatalog-df-pf-null-ww>

CD4528BMJ - <http://www.ti.com/product/cd4528bmj?HQS=TI-null-null-dscatalog-df-pf-null-ww>

CD4528BCN - <http://www.ti.com/product/cd4528bcn?HQS=TI-null-null-dscatalog-df-pf-null-ww>

4528B - <http://www.ti.com/product/4528b?HQS=TI-null-null-dscatalog-df-pf-null-ww>

CD4528BCJ - <http://www.ti.com/product/cd4528bcj?HQS=TI-null-null-dscatalog-df-pf-null-ww>

CD4528 - <http://www.ti.com/product/cd4528?HQS=TI-null-null-dscatalog-df-pf-null-ww>